

## Three-terminal positive voltage regulator

### FEATURES

- Maximum output current I<sub>OM</sub>: 0.1A
- Output voltage V<sub>O</sub>: 6V
- Continuous total dissipation  
PD: 0.625 W    T<sub>A</sub>=25°C

### MECHANICAL DATA

- Case: TO-92 Small Outline Plastic Package
- Polarity: Color band denotes cathode end
- Mounting Position: Any

### TO-92

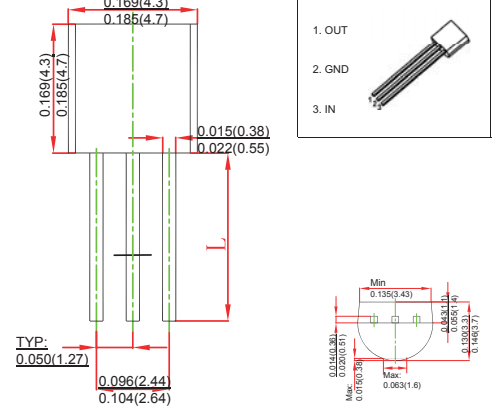

## MAXIMUM RATINGS AND CHARACTERISTICS

@ 25°C Ambient Temperature (unless otherwise noted)

Parameter	Symbol	Value	Unit
Input Voltage	V <sub>i</sub>	30	V
Thermal Resistance from Junction to Ambient	R <sub>θJA</sub>	160	°C/W
Operating Junction Temperature Range	T <sub>OPR</sub>	-25~+125	°C
Storage Temperature Range	T <sub>STG</sub>	-65~+150	°C

## ELECTRICAL CHARACTERISTICS AT SPECIFIED VIRTUAL JUNCTION TEMPERATURE

(V<sub>i</sub>=10V, I<sub>o</sub>=40mA, C<sub>i</sub>=0.33μF, C<sub>o</sub>=0.1μF, unless otherwise specified)

Parameter	Symbol	Test conditions	Min	Typ	Max	Unit	
Output voltage	V <sub>o</sub>	25°C	5.75	6.0	6.25	V	
		-125°C	8V ≤ V <sub>i</sub> ≤ 20V, I <sub>o</sub> = 1mA-40mA	5.7	6.0	6.3	V
			I <sub>o</sub> = 1mA-70mA	5.7	6.0	6.3	V
Load Regulation	ΔV <sub>o</sub>	I <sub>o</sub> = 1mA-100mA	25°C	16	80	mV	
		I <sub>o</sub> = 1mA-40mA	25°C	9	40	mV	
Line regulation	ΔV <sub>o</sub>	8V ≤ V <sub>i</sub> ≤ 20V	25°C	35	175	mV	
		9V ≤ V <sub>i</sub> ≤ 20V	25°C	29	125	mV	
Quiescent Current	I <sub>q</sub>	25°C	3.9	6.0	mA		
Quiescent Current Change	ΔI <sub>q</sub>	9V ≤ V <sub>i</sub> ≤ 20V	-125°C		1.5	mA	
		1mA ≤ I <sub>o</sub> ≤ 40mA	-125°C		0.1	mA	
Output Noise Voltage	V <sub>N</sub>	10Hz ≤ f ≤ 100KHz	25°C	46		8V/V <sub>o</sub>	
Ripple Rejection	RR	9V ≤ V <sub>i</sub> ≤ 19V, f = 120Hz	-125°C	40	4	dB	
Dropout Voltage	V <sub>d</sub>	25°C		1.7		V	

\* Pulse test.

### TYPICAL APPLICATION

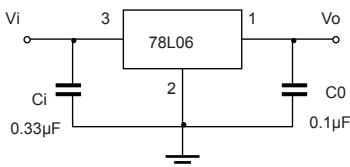

# RATINGS AND CHARACTERISTIC CURVES

## Typical Characteristics

